



Professional

GBH 240 | GBH 240 F

Robert Bosch Power Tools GmbH
70538 Stuttgart
GERMANY

www.bosch-pt.com

1 609 92A 891 (2025.12) TAG / 15



1 609 92A 891



en Original instructions







GBH 240 F

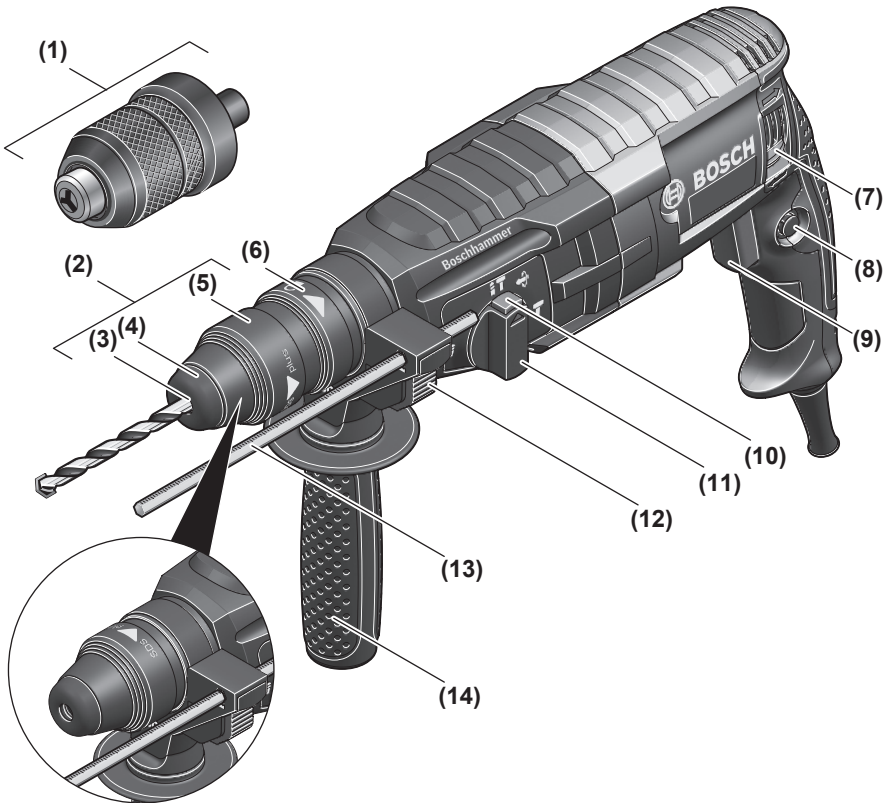

GBH 240



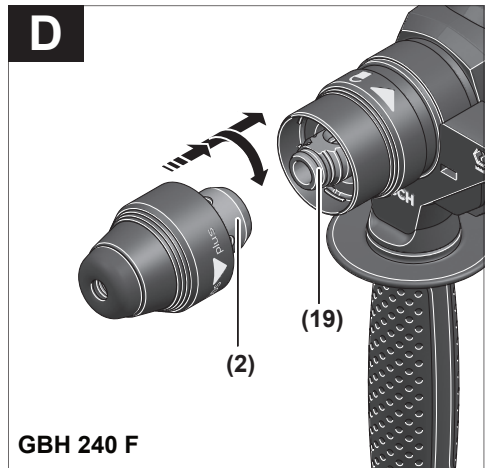
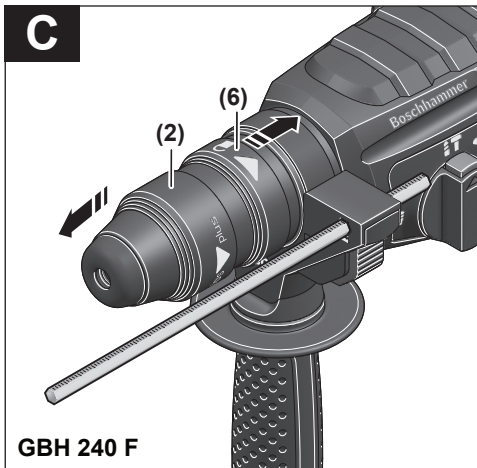
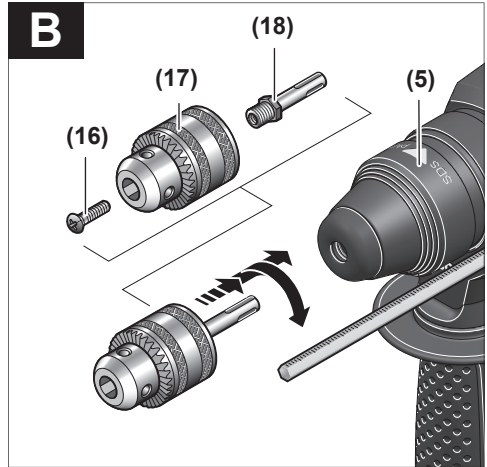
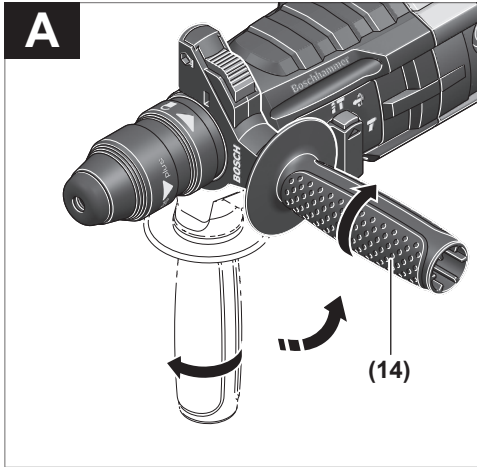



English

Safety instructions

General Power Tool Safety Warnings

⚠️ WARNING Read all safety warnings, instructions, illustrations and specifications provided with this power tool. Failure to follow all instructions listed below may result in electric shock, fire and/or serious injury.

Save all warnings and instructions for future reference.

The term "power tool" in the warnings refers to your mains-operated (corded) power tool or battery-operated (cordless) power tool.

Work area safety

- ▶ **Keep work area clean and well lit.** Cluttered or dark areas invite accidents.
- ▶ **Do not operate power tools in explosive atmospheres, such as in the presence of flammable liquids, gases or dust.** Power tools create sparks which may ignite the dust or fumes.
- ▶ **Keep children and bystanders away while operating a power tool.** Distractions can cause you to lose control.

Electrical safety

- ▶ **Power tool plugs must match the outlet. Never modify the plug in any way. Do not use any adapter plugs with earthed (grounded) power tools.** Unmodified plugs and matching outlets will reduce risk of electric shock.
- ▶ **Avoid body contact with earthed or grounded surfaces, such as pipes, radiators, ranges and refrigerators.** There is an increased risk of electric shock if your body is earthed or grounded.
- ▶ **Do not expose power tools to rain or wet conditions.** Water entering a power tool will increase the risk of electric shock.
- ▶ **Do not abuse the cord. Never use the cord for carrying, pulling or unplugging the power tool. Keep cord away from heat, oil, sharp edges or moving parts.** Damaged or entangled cords increase the risk of electric shock.
- ▶ **When operating a power tool outdoors, use an extension cord suitable for outdoor use.** Use of a cord suitable for outdoor use reduces the risk of electric shock.
- ▶ **If operating a power tool in a damp location is unavoidable, use a residual current device (RCD) protected supply.** Use of an RCD reduces the risk of electric shock.

Personal safety

- ▶ **Stay alert, watch what you are doing and use common sense when operating a power tool. Do not use a power tool while you are tired or under the influence of drugs, alcohol or medication.** A moment of inatten-

tion while operating power tools may result in serious personal injury.

- ▶ **Use personal protective equipment. Always wear eye protection.** Protective equipment such as a dust mask, non-skid safety shoes, hard hat or hearing protection used for appropriate conditions will reduce personal injuries.
- ▶ **Prevent unintentional starting. Ensure the switch is in the off-position before connecting to power source and/or battery pack, picking up or carrying the tool.** Carrying power tools with your finger on the switch or engaging power tools that have the switch on invites accidents.
- ▶ **Remove any adjusting key or wrench before turning the power tool on.** A wrench or a key left attached to a rotating part of the power tool may result in personal injury.
- ▶ **Do not overreach. Keep proper footing and balance at all times.** This enables better control of the power tool in unexpected situations.
- ▶ **Dress properly. Do not wear loose clothing or jewellery. Keep your hair and clothing away from moving parts.** Loose clothes, jewellery or long hair can be caught in moving parts.
- ▶ **If devices are provided for the connection of dust extraction and collection facilities, ensure these are connected and properly used.** Use of dust collection can reduce dust-related hazards.
- ▶ **Do not let familiarity gained from frequent use of tools allow you to become complacent and ignore tool safety principles.** A careless action can cause severe injury within a fraction of a second.

Power tool use and care

- ▶ **Do not force the power tool. Use the correct power tool for your application.** The correct power tool will do the job better and safer at the rate for which it was designed.
- ▶ **Do not use the power tool if the switch does not turn it on and off.** Any power tool that cannot be controlled with the switch is dangerous and must be repaired.
- ▶ **Disconnect the plug from the power source and/or remove the battery pack, if detachable, from the power tool before making any adjustments, changing accessories, or storing power tools.** Such preventive safety measures reduce the risk of starting the power tool accidentally.
- ▶ **Store idle power tools out of the reach of children and do not allow persons unfamiliar with the power tool or these instructions to operate the power tool.** Power tools are dangerous in the hands of untrained users.
- ▶ **Maintain power tools and accessories. Check for misalignment or binding of moving parts, breakage of parts and any other condition that may affect the power tool's operation. If damaged, have the power tool repaired before use.** Many accidents are caused by poorly maintained power tools.

- ▶ **Keep cutting tools sharp and clean.** Properly maintained cutting tools with sharp cutting edges are less likely to bind and are easier to control.
- ▶ **Use the power tool, accessories and tool bits etc. in accordance with these instructions, taking into account the working conditions and the work to be performed.** Use of the power tool for operations different from those intended could result in a hazardous situation.
- ▶ **Keep handles and grasping surfaces dry, clean and free from oil and grease.** Slippery handles and grasping surfaces do not allow for safe handling and control of the tool in unexpected situations.

Service

- ▶ **Have your power tool serviced by a qualified repair person using only identical replacement parts.** This will ensure that the safety of the power tool is maintained.

Hammer Safety Warnings

Safety instructions for all operations

- ▶ **Wear ear protectors.** Exposure to noise can cause hearing loss.
- ▶ **Use auxiliary handle(s), if supplied with the tool.** Loss of control can cause personal injury.
- ▶ **Hold the power tool by insulated gripping surfaces, when performing an operation where the cutting accessory or fasteners may contact hidden wiring or its own cord.** Cutting accessory or fasteners contacting a "live" wire may make exposed metal parts of the power tool "live" and could give the operator an electric shock.

Safety instructions when using long drill bits with rotary hammers

- ▶ **Always start drilling at low speed and with the bit tip in contact with the workpiece.** At higher speeds, the bit is likely to bend if allowed to rotate freely without contacting the workpiece, resulting in personal injury.
- ▶ **Apply pressure only in direct line with the bit and do not apply excessive pressure.** Bits can bend, causing breakage or loss of control, resulting in personal injury.

Additional safety information

- ▶ **Use suitable detectors to determine if utility lines are hidden in the work area or call the local utility company for assistance.** Contact with electric lines can lead to fire and electric shock. Damaging a gas line can lead to explosion. Penetrating a water line causes property damage or may cause an electric shock.
- ▶ **Always wait until the power tool has come to a complete stop before placing it down.** The application tool can jam and cause you to lose control of the power tool.
- ▶ **Secure the workpiece.** A workpiece clamped with clamping devices or in a vice is held more secure than by hand.
- ▶ **Products sold in GB only:**
Your product is fitted with an BS 1363/A approved electric plug with internal fuse (ASTA approved to BS 1362). If the plug is not suitable for your socket outlets, it should

be cut off and an appropriate plug fitted in its place by an authorised customer service agent. The replacement plug should have the same fuse rating as the original plug.

The severed plug must be disposed of to avoid a possible shock hazard and should never be inserted into a mains socket elsewhere.

- ▶ **Do not touch any application tools or adjacent housing components shortly after operation.** These can become very hot during operation and cause burns.
- ▶ **The application tool may jam during drilling. Make sure you have a stable footing and hold the power tool firmly with both hands.** Otherwise you could lose control of the power tool.
- ▶ **Take care when carrying out demolition work using the chisel.** Falling fragments of the demolition material could injure you or any bystanders.
- ▶ **Hold the power tool firmly with both hands and make sure you have a stable footing.** The power tool can be more securely guided with both hands.

Product Description and Specifications



Read all the safety and general instructions.

Failure to observe the safety and general instructions may result in electric shock, fire and/or serious injury.

Please observe the illustrations at the beginning of this operating manual.

Intended Use

The power tool is intended for hammer drilling in concrete, brick and stone, as well as for light chiselling work. It is also suitable for drilling without impact in wood, metal, ceramic and plastic. Power tools with electronic control and right/left rotation are also suitable for screwdriving.

Product Features

The numbering of the product features refers to the diagram of the power tool on the graphics page.

- (1) Keyless quick-change chuck (GBH 240 F)
- (2) SDS plus quick-change chuck (GBH 240 F)
- (3) SDS plus tool holder
- (4) Dust protection cap
- (5) Locking sleeve
- (6) Locking ring for quick-change chuck (GBH 240 F)
- (7) Rotational direction switch
- (8) Lock-on button for on/off switch
- (9) On/off switch
- (10) Release button for impact/mode selector switch
- (11) Impact/mode selector switch
- (12) Button for depth stop adjustment
- (13) Depth stop

- (14) Auxiliary handle (insulated gripping surface)
 (15) Handle (insulated gripping surface)
 (16) Securing screw for keyed chuck^{a)}
 (17) Keyed chuck^{a)}
 (18) SDS plus shank for drill chuck^{a)}
 (19) Drill chuck holder (GBH 240 F)
- (20) Front sleeve of the keyless quick-change chuck (GBH 240 F)
 (21) Retaining ring of the keyless quick-change chuck (GBH 240 F)
 (22) Universal holder with SDS plus shank^{a)}
- a) **This accessory is not part of the standard scope of delivery.**

Technical Data

Rotary Hammer		GBH 240	GBH 240 F
Article number		3 611 B72 1..	3 611 B73 0..
Speed control		●	●
Stop rotation		●	●
Clockwise/anticlockwise rotation		●	●
Quick-change chuck		-	●
Rated power input	W	790	790
Impact rate	min ⁻¹	0–4200	0–4200
Rated speed	min ⁻¹	0–930	0–930
Tool holder		SDS plus	SDS plus
Spindle collar diameter	mm	48.5	48.5
Max. drilling diameter:			
– Concrete	mm	24	24
– Masonry (with hollow core bit)	mm	68	68
– Steel	mm	13	13
– Wood	mm	30	30
Weight ^{A)}	kg	2.8	2.9
Protection class		□ / II	□ / II

A) With auxiliary handle (14), without mains connection cable

The specifications apply to a rated voltage [U] of 230 V. These specifications may vary at different voltages and in country-specific models.

Values can vary depending on the product, scope of application and environmental conditions. To find out more, visit www.bosch-professional.com/wac.

Noise/Vibration Information

Noise emission values determined according to **EN IEC 62841-2-6**.

Typically, the A-weighted noise level of the power tool is: Sound pressure level **96 dB(A)**; sound power level **104 dB(A)**. Uncertainty K = **3 dB**.

Wear hearing protection!

Vibration values a_h (continuous vibrations), p_F (repeated shock vibrations) and uncertainty K determined according to **EN IEC 62841-2-6**:

GBH 240:

Hammer drilling in concrete: $a_{h,HD} = 15.9 \text{ m/s}^2$ (K = **1.5** m/s²), $p_{F,HD} = 391 \text{ m/s}^2$ (K = **75** m/s²)

Chiselling: $a_{h,CHeq} = 9.3 \text{ m/s}^2$ (K = **1.5** m/s²), $p_{F,CHeq} = 552 \text{ m/s}^2$ (K = **12** m/s²)

GBH 240 F:

Hammer drilling in concrete: $a_{h,HD} = 15.5 \text{ m/s}^2$ (K = **1.5** m/s²), $p_{F,HD} = 461 \text{ m/s}^2$ (K = **62** m/s²)

Chiselling: $a_{h,CHeq} = 11 \text{ m/s}^2$ (K = **1.5** m/s²), $p_{F,CHeq} = 686 \text{ m/s}^2$ (K = **40** m/s²)

The vibration level and noise emission value given in these instructions have been measured in accordance with a standardised measuring procedure and may be used to compare power tools. They may also be used for a preliminary estimation of vibration and noise emissions.

The stated vibration level and noise emission value represent the main applications of the power tool. However, if the power tool is used for other applications, with different accessories or is poorly maintained, the vibration level and noise emission value may differ. This may significantly increase the vibration and noise emissions over the total working period.

To estimate vibration and noise emissions accurately, the times when the tool is switched off or when it is running but not actually being used should also be taken into account. This may significantly reduce vibration and noise emissions over the total working period.

Implement additional safety measures to protect the operator from the effects of vibration, such as servicing the power tool and accessories, keeping their hands warm, and organising workflows correctly.

Assembly

- ▶ **Pull the plug out of the socket before carrying out any work on the power tool.**

Auxiliary handle

- ▶ **Do not operate your power tool without the auxiliary handle (14).**
- ▶ **Make sure that the auxiliary handle is always tightened.** Otherwise you could lose control of the power tool when working.

Swivelling the auxiliary handle (see figure A)

You can swivel the auxiliary handle (14) to any angle for a safe work posture that minimises fatigue.

- Turn the lower gripping end of the auxiliary handle (14) anticlockwise and swivel the auxiliary handle (14) into the required position. Then turn the lower gripping end of the auxiliary handle (14) clockwise to retighten it. Make sure that the retaining strap of the auxiliary handle slots into the corresponding groove of the housing.

Selecting drill chucks and tools

For hammer drilling and chiselling, you will need SDS plus tools, which insert into the SDS plus drill chuck.

For drilling without impact in wood, metal, ceramic and plastic as well as for screwdriving, tools without SDS plus are used (e.g. cylindrical shank drill bits). For these tools, a keyless chuck or a keyed chuck are required.

Note: Only use the keyed chuck in the **drilling without impact** operating mode.

GBH 240 F: The SDS plus quick-change chuck (2) can easily be swapped with the keyless quick-change chuck (1) supplied.

Changing the drill chuck

Inserting/removing the keyed chuck

GBH 240

You must use a suitable drill chuck (keyed or keyless chuck) to work with tools that do not have SDS plus (e.g. cylindrical shank drill bits).

Fitting the keyed chuck (see figure B)

- Screw the SDS plus shank (18) into a keyed chuck (17). Secure the keyed chuck (17) using the securing screw (16). **Note that the securing screw has a left-hand thread.**

Inserting the keyed chuck (see figure B)

- Clean and lightly grease the insertion end of the shank.
- Insert the keyed chuck with the adapter shank into the tool holder with a turning motion until it automatically locks.

- Check that it is locked by pulling the keyed chuck.

Removing the keyed chuck

- Push the locking sleeve (5) back and remove the keyed chuck (17).

Removing/inserting the quick-change chuck

GBH 240 F

Removing the Quick-Change Chuck (see figure C)

- Pull back on the quick-change chuck locking ring (6), hold it in this position and pull the SDS plus quick-change chuck (2) or the keyless quick-change chuck (1) out from the front.
- Once the quick-change chuck is removed, protect it from dirt.

Inserting the Quick-change Chuck (see figure D)

- Before insertion, clean the quick-change chuck and lightly grease the shank.
- Wrap your whole hand around the SDS plus quick-change chuck (2) or the keyless quick-change chuck (1). Use a turning motion to push the quick-change chuck into the drill chuck holder (19) until you hear it click into place.
- The quick-change chuck is automatically locked. Check that it is locked by pulling on the quick-change chuck.

Changing the tool

The dust protection cap (4) largely prevents the penetration of drilling dust into the tool holder during operation. When inserting the tool, make sure that the dust protection cap (4) does not become damaged.

- ▶ **Replace a damaged dust protection cap immediately. It is recommended that you have use an after-sales service for this.**

Changing the tool SDS plus

Inserting the SDS plus Application Tool (see figure E)

The SDS plus drill chuck enables you to change the application tool easily and conveniently without needing to use additional tools.

- **GBH 240 F:** Insert the SDS plus quick-change chuck (2).
- Clean and lightly grease the shank of the application tool.
- Insert the application tool into the tool holder while turning it until it locks automatically.
- Check that it is locked by pulling on the tool.

As a requirement of the system, the SDS plus application tool can move freely. This causes a certain radial run-out at no-load, which has no effect on the accuracy of the drill hole, as the drill bit centres itself upon drilling.

Removing the SDS plus Application Tool (see figure F)

- Push the locking sleeve (5) back and remove the application tool.

Changing the keyed chuck

GBH 240

Inserting the application tool

Note: Application tools that do not have SDS plus must not be used for hammer drilling or chiselling. Tools without

SDS plus and their drill chucks are damaged by hammer drilling or chiselling.

- Insert a keyed chuck (17).
- Open the keyed chuck (17) by turning it until the tool can be inserted. Insert the tool.
- Insert the chuck key into the corresponding holes of the keyed chuck (17) and clamp the tool evenly.
- Turn the impact/mode selector switch (11) to the "drilling" position.

Removing the application tool

- Use the chuck key to turn the sleeve of the keyed chuck (17) anticlockwise until the application tool can be removed.

Changing the keyless quick-change chuck

GBH 240 F

Inserting the application tool (see figure G)

Note: Application tools that do not have SDS plus must not be used for hammer drilling or chiselling. Tools without SDS plus and their drill chucks are damaged by hammer drilling or chiselling.

- Insert the keyless quick-change chuck (1).
- Hold the retaining ring (21) of the keyless quick-change chuck firmly in place. Open the tool holder by turning the front sleeve (20) until the tool can be inserted. Hold the retaining ring (21) in place and firmly tighten the front sleeve (20) by turning it in the direction of the arrow until you hear it click into place.
- Check that it is seated securely by pulling on the tool.

Note: If the tool holder was unscrewed all the way, a scraping sound may be heard while retightening the tool holder and it may not fully tighten.

In this case, turn the front sleeve (20) in the opposite direction to the arrow by one full turn. This will allow the tool holder to be fully tightened.

- Turn the impact/mode selector switch (11) to the "drilling" position.

Removing the application tool (see figure H)

- Hold the retaining ring (21) of the keyless quick-change chuck firmly in place. Open the tool holder by turning the front sleeve (20) in the direction of the arrow until the tool can be removed.

Dust Reduction

Do not perform work without taking dust-reducing measures. Depending on the intended application, the power tool can be combined with a dust-reducing accessory together with a dust extractor.

Always use suitable breathing protection. The regulations on the materials being machined that apply in the country of use must be observed.

- ▶ **Avoid dust accumulation at the workplace.** Dust can easily ignite.

Requirements for the Dust Extractor

Recommended hose nominal diameter	mm	35
-----------------------------------	----	----

Requirements for the Dust Extractor

Required vacuum pressure ^{A)}	mbar	≥ 230
	hPa	≥ 230
Required flow rate ^{A)}	l/s	≥ 36
	m ³ /h	≥ 129.6
Recommended filter efficiency	Dust class M ^{B)}	

A) Power value at the power tool's dust extractor connection

B) According to IEC/EN 60335-2-69

Refer to the dust extractor's instructions. If there is reduced suction power, stop working and eliminate the cause.

Operation

- ▶ **Products that are only sold in AUS and NZ:** Use a residual current device (RCD) with a nominal residual current of 30 mA or less.

Start-up

- ▶ **Pay attention to the mains voltage.** The voltage of the power source must match the voltage specified on the rating plate of the power tool.

Setting the operating mode

The operating mode of the power tool is selected using the impact/mode selector switch (11).

- To change the operating mode, press the release button (10) and turn the impact/mode selector switch (11) until it clicks into the required position.

Note: Only change the operating mode when the power tool is switched off. Otherwise, the power tool may become damaged.

Position for **hammer drilling** into concrete or stone

Position for **drilling** without impact in wood, metal, ceramic and plastic and for **screwdriving**

Vario-Lock position for adjusting the chisel position
The impact/mode selector switch (11) will not engage in this position.

Position for **chiselling**



Setting the rotational direction

The rotational direction switch (7) is used to change the rotational direction of the power tool. However, this is not possible while the on/off switch (9) is being pressed.

- ▶ **Only operate the rotational direction switch (7) when the power tool is not in use.**

Always set the rotational direction to clockwise rotation for hammer drilling, drilling and chiselling.

- **Rotate clockwise:** Turn the rotational direction switch (7) on both sides until it stops in the ◀ position.
- **Rotate anticlockwise:** Turn the rotational direction switch (7) on both sides until it stops in the ▶ position.

Switching On/Off

- To **switch on** the power tool, press the on/off switch (9).
- To **lock** the on/off switch (9), press and hold it while also pushing the lock-on button (8).
- To **switch off** the power tool, release the on/off switch (9). If the on/off switch (9) is locked, press the switch first and then release it.

Adjusting the speed/impact rate

You can adjust the speed/impact rate of the power tool when it is on by pressing in the on/off switch (9) to varying extents.

Applying light pressure to the on/off switch (9) results in a low rotational speed/impact rate. Applying increasing pressure to the switch increases the speed/impact rate.

Changing the chiselling position (Vario-Lock)

You can lock the chisel in 36 different positions, so you can select the optimum working position for each task.

- Insert the chisel into the tool holder.
- Turn the impact/mode selector switch (11) to the "Vario-Lock" position.
- Turn the application tool to the required chisel position.
- Turn the impact/mode selector switch (11) to the "chiselling" position. With this, the tool holder is locked.
- Set the rotational direction for chiselling to clockwise.

Practical advice

Setting the drilling depth (see figure I)

You can use the depth stop (13) to set the required drilling depth X.

- Press the button for depth stop adjustment (12) and insert the depth stop into the auxiliary handle (14). The fluting on the depth stop (13) must face downwards.
- Push the SDS plus application tool into the SDS plus tool holder (3) as far as it will go. Otherwise, the movability of the SDS plus drilling tool can lead to incorrect adjustment of the drilling depth.
- Pull the depth stop far enough out that the distance between the drill bit tip and the edge of the depth stop corresponds to the required drilling depth X.

Overload clutch

- ▶ **If the application tool jams or snags, the power transmission to the drill spindle will be interrupted. Always hold the power tool firmly with both hands to withstand the forces this may create and adopt a position with stable footing.**
- ▶ **Switch the power tool off immediately and remove the application tool if the power tool becomes blocked. Switching on when the application tool is blocked may cause high torque reactions.**

Inserting screwdriver bits (see figure J)

- ▶ **Only apply the power tool to the screw/nut when the tool is switched off.** Rotating tool inserts can slip off.

A universal holder (22) with SDS plus shank is required to work with screwdriver bits.

- Clean and lightly grease the insertion end of the shank.
- Insert the universal holder into the tool holder while turning it until it locks automatically.
- Check that it is locked by pulling the universal holder.
- Insert a screwdriver bit in the universal holder. Only use screwdriver bits that fit the screw head.
- To remove the universal holder, slide the locking sleeve (5) backwards and remove the universal holder (22) from the tool holder.

Maintenance and Service

Maintenance and cleaning

- ▶ **Pull the plug out of the socket before carrying out any work on the power tool.**
- ▶ **To ensure safe and efficient operation, always keep the power tool and the ventilation slots clean.**

In order to avoid safety hazards, if the power supply cord needs to be replaced, this must be done by **Bosch** or by an after-sales service centre that is authorised to repair **Bosch** power tools.

- ▶ **Replace a damaged dust protection cap immediately. It is recommended that you have use an after-sales service for this.**
- Clean the tool holder (3) after each use.

After-Sales Service and Application Service

Great Britain

Tel. Service: (0344) 7360109

GB Importer:

Robert Bosch Ltd.
Broadwater Park
North Orbital Road
Uxbridge
UB9 5HJ

In all correspondence and spare parts orders, please always include the 10-digit article number given on the nameplate of the product.

Disposal

The power tool, accessories and packaging should be recycled in an environmentally friendly manner.



Do not dispose of power tools along with household waste.

Only for EU countries and United Kingdom:

Electrical and electronic equipment that is no longer suitable for use must be collected separately and disposed of in an

environmentally friendly manner. Use the designated collection systems. Incorrect disposal may cause harmful effects on the environment and human health, due to the potential presence of hazardous substances.



2 607 000 207

1 613 001 010

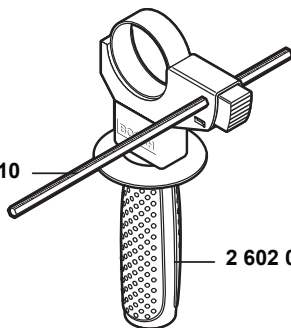

2 602 025 141



2 608 550 074 (Ø 40 mm)

2 608 550 075 (Ø 50 mm)

2 608 550 076 (Ø 68 mm)



2 605 438 098

2 608 550 057
Ø 8 mm2 608 596 157
Ø 8 mm

2 608 002 021

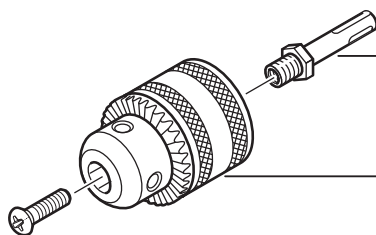
GBH 2401 617 000 132
SDS plus1 608 571 062
Ø 1,5 - 13 mm**GBH 240 F**2 608 572 212
Ø 50 mm

1 607 950 045

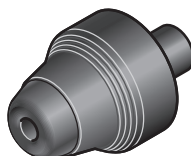
2 608 572 213
SDS plus
Ø 50 mm

Servicekontakte
Service Contacts
Contacts de Service
Contactos de Servicio



<https://www.bosch-pt.com/serviceaddresses>

Garantiebedingungen
Guarantee Conditions
Conditions de Garantie
Condiciones de Garantía



<https://www.bosch-pt.com/guarantee/202507>